



# **WEDGE GATE VALVE**

---

Proudly Manufactured in South Africa

**Size :** DN 50 to DN 1800

**Pressure class :** Up to PN 40

**Features :**

- Designed and manufactured in accordance with SABS 664 & SABS 665
- Non-rising spindle & rising spindle option
- Adjustable PTFE stem packing
- Replaceable gate and wedge seat
- Wedge guide ribs are provided with wear shoe from DN 300v

**Drilling standard :**

Drilling as per SANS 1123, BS 10 & En1092.

**Coating :**

Internal and external surfaces are coated with epoxy not less than 250 microns DFT.

**Operation :**

Valves can be operated by means of gearbox with cap-top (T-key), hand-wheel or electrical actuator. Extension spindles & pedestals can be provided for valves installed at the dams lowest level. The valve closing direction is to BS 5153 or SANS 664/665 or as per contractual requirements. Hydraulic cylinder operated gate valves are also available on request.

**Material of construction**

Component	Specification	
	Up to PN25	PN40 & above
Gate	Ductile iron	Steel
Body seat	Stainless steel 316 ring or weld deposit	
Body	Ductile iron	Steel
Bonnet	Ductile iron	Steel
Shaft	Stainless steel BS970 431S29	
Thrust housing	Ductile iron	Steel
Stuffing box	Ductile iron	
Gland	Ductile iron	
Gate seat	Nickel Aluminum bronze AB1 ring or weld deposit	



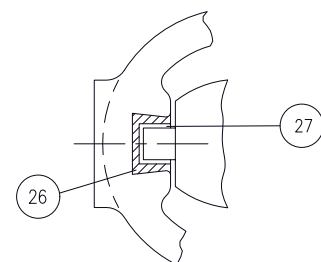
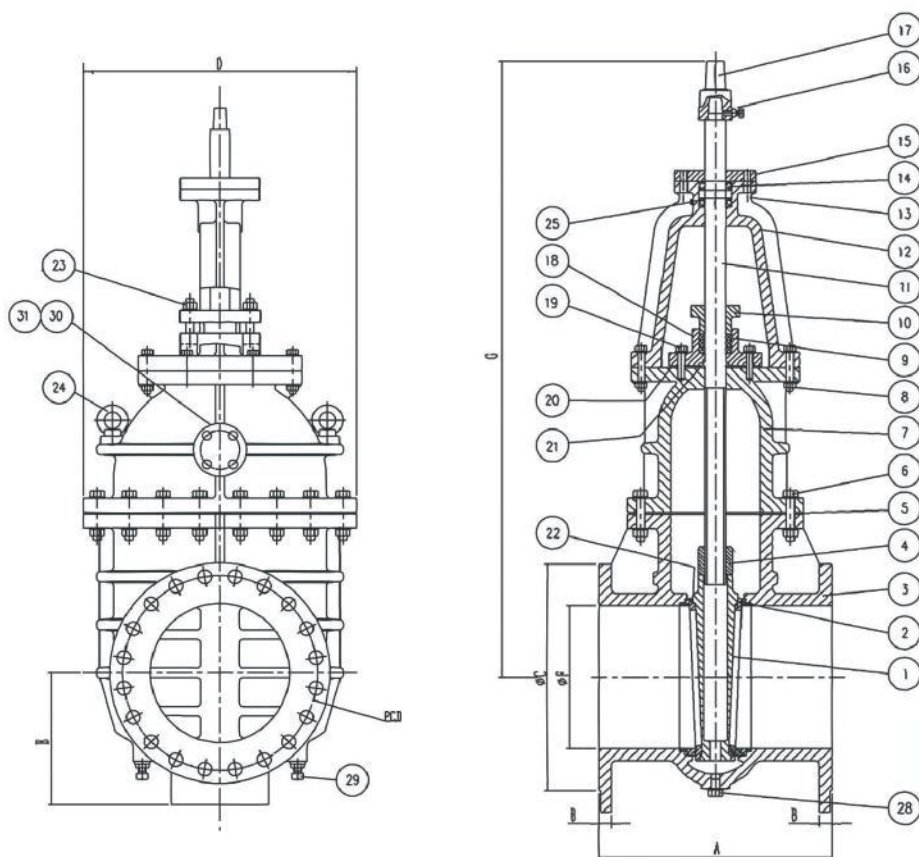

DETAIL OF BODY GUIDE & GATE SHOE

SI no	Description	Material
1	Gate	BS 3100 A2/A216 Gr. WCB
2	Body seal	ST/Steel 316 weld deposit/Gunmetal LG2 ring
3	Body	BS 3100 A2/A216 Gr. WCB
4	Gate nut	NA Bronze-AB2
5	Body gasket	Asbestos free
6	Body bolting	Steel/Gr 8.8
7	Bonnet	BS 3100 A2/A216 Gr. WCB
8	Thrust housing bolting	Steel/Gr 8.8
9	Gland packing	PTFE
10	Gland	ST/Steel 304
11	Spindle	ST/Steel BS 970 431S29
12	Thrust housing	CS BS 3100-A2/A216 Gr WCB/SG BS2789-420/12
13	Thrust plate bolting	Steel/Gr 8.8
14	Thrust bearing	Steel cadmium plated
15	Thrust plate	Mild steel
16	Captop bolting	Steel/Gr 4.6
17	Captop	SG BS2789-420/2/EN 1563 GJS 400 15/18
18	Stuffing box	SG BS2789-420/2/EN 1563 GJS 400 15/18
19	Stuffing box bolting	Steel/Gr 8.8
20	Stuffing box gasket	Asbestos free
21	U-seal	Nitrile rubber
22	Gate seat	NA Bronze-AB1 weld deposit/Gunmetal LG2 ring
23	Gland bolting	Steel/Gr 8.8
24	Eye-bolt	H.T. Steel
25	Grease nipple	Steel-galvanised
26	Body guide	GM BS 1400 LG2
27	Gate shoe	NA Bronze-AB1 weld deposit
28	Drain plug	Steel-galvanised
29	Limit stop	ST/Steel BS970 431S29
30	Inspection gasket	Nitrile rubber
31	Inspection cover	Mild steel

MAIN SLUICE VALVE

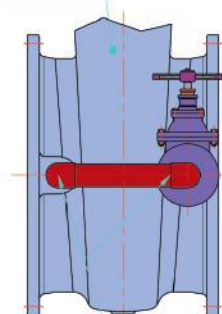

BY-PASS SLV

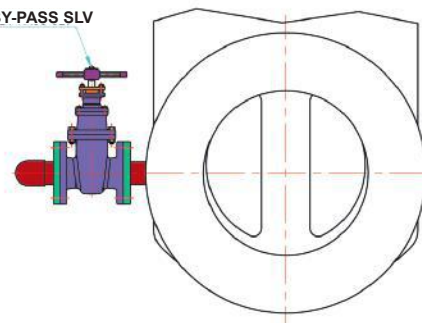

BENDS/ELBOWS FITTINGS



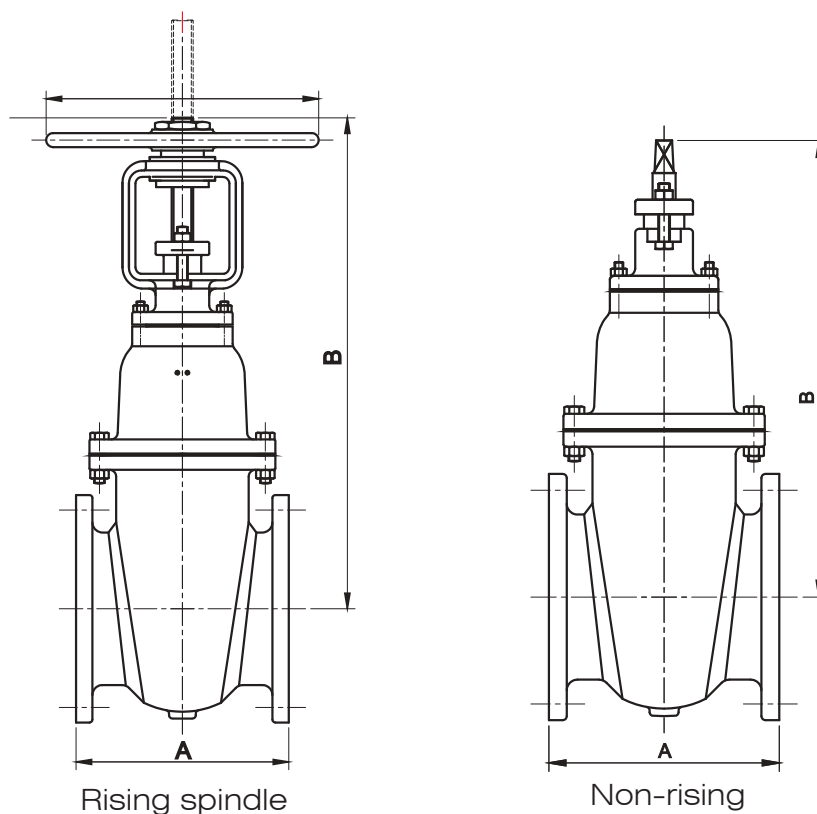

Rising spindle

Non-rising

Flanged End (SANS 664 & 665) (PN 16, 25 & 40)							
Size	Face to face				Center to top		
	664		665		664 & 665		
(DN)	PN 16	PN 25 & 40	PN 16	PN 25 & 40	NRS	RS (closed)	RS (open)
50	216	216	178	216	230	280	350
80	229	283	203	283	285	390	490
100	254	305	229	305	331	450	570
150	280	403	267	403	438	598	768
200	317	419	292	419	565	770	990
250	356	457	330	457	711	890	1160
300	380	502	356	502	800	1040	1360
350	470	572	381	572	810	1165	1535
400	470	610	406	610	890	1310	1730
450	485	660	432	660	975	1425	1895
500	510	711	457	711	1050	1550	2070
600	600	787	508	787	1238	1838	2458
700	610	863	610	863	1575	2275	2995
800	660	950	660	950	1688	2488	3308
900	711	1020	711	1020	1800	2700	3620
1000	811	1100	811	1100	1913	2913	3933
1100	911	1180	911	1180	2025	3200	4320
1200	1011	1260	1011	1260	2138	3450	4670
1400	1250	1340	1250	1340	2250	4250	5670
1500	1275	1420	1275	1420	2363	4560	6080
1600	1350	1500	1350	1500	2475	4580	6200
1800	1550	1660	1550	1660	2700	5860	7680

NRS Non- Rising Spindle

RS Rising Spindle

Larger sizes available on request

As a part of continuous improvement process, the above details are subject to change without notice.



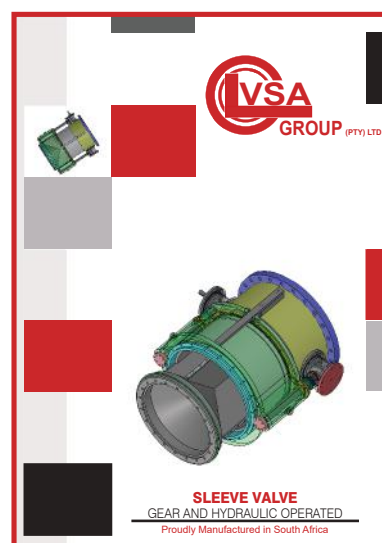

## **LVSA Group Pty Ltd - Durban - Manufacturing Facility**

8 Uitsig Road, Astra Park, Kingsburgh, Durban, South Africa.

Telephone : +27 (0) 31 914 1025

Email : kznsales@lvsagroup.co.za

## **Distribution Offices**

### **LVSA Group - Johannesburg**

46 Kindon Road, Robertsham, Johannesburg, South Africa, 2091.

Telephone : +27 (0) 11 680 2005

Fax: +27 (0) 11 680 2016

Email : sales@lvsagroup.co.za

### **LVSA Group - Cape Town**

97 Neil Hare Rd, Atlantis Industrial, Cape Town, 7349, South Africa

Telephone: +27 21 534 2451

Email : ctsales@lvsagroup.co.za

### **LVSA Limitada - Mozambique**

Avenida Unido Africana numero 759, armazém 7,

Matola - Mozambique

Telephone: +258 83 911 1111

Email : info@lvsa.co.mz

[www.lvsagroup.co.za](http://www.lvsagroup.co.za)